

SBS Format Combo

I. APPLICATIONS

1. Sample collection
2. Sample transportation
3. Sample storage
4. Dispensing samples

II. FEATURES

1. Racks: 2D barcode and human readable numbers on the side, 2D barcode on the bottom; Vials: 2D barcode on the bottom
2. Simple and powerful mechanical locking performance, slide the buttons on two sides of the rack to unlock
3. Blue via lcaps and racks
4. Working temperature: stable from -196°C to 121°C
5. Suitable for liquid nitrogen freezing

III. DESIGN

1. Vials, caps and the rack in one package, convenient to use
2. Two codes on racks and 2D barcodes on vials enable quick scan and easy orientation
3. Vacuum packaging, foreign DNA free, DNase & RNase free, gamma radiation.

IV. PACKAGING

Item	Description	Packaging	Sterile
89-4033	300µl Vials+Rack, 96-well	1 Sets/Bag , 10 Bags/Pack , 2 Packs/Case	Yes
89-4053	500µl Vials+Rack, 96-well	1 Sets/Bag , 10 Bags/Pack , 2 Packs/Case	Yes
89-4083	750µl Vials+Rack, 96-well	1 Sets/Bag , 10 Bags/Pack , 2 Packs/Case	Yes
89-4103	1000µl Vials+Rack, 96-well	1 Sets/Bag , 10 Bags/Pack , 2 Packs/Case	Yes

V. STERILITY

For each lot, sterilization records are recorded and signed off by qualified personnel for product release.

VI. CERTIFICATION

Biologix products are manufactured completely according to the TUV ISO 9001:2008 standard.

VII. PRODUCT PARAMETER

Dimensions=mm

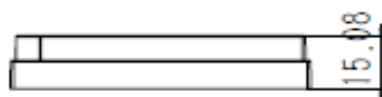
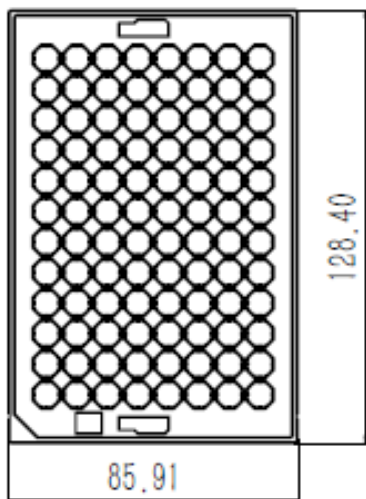
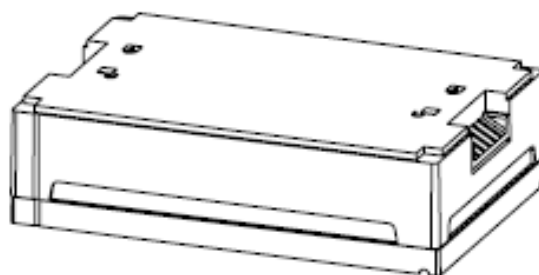
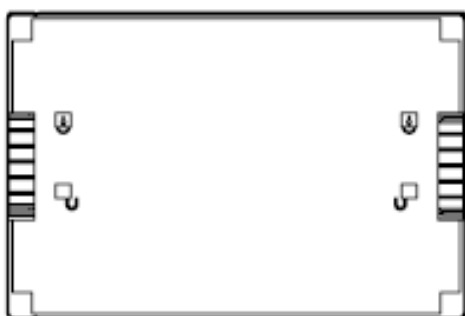
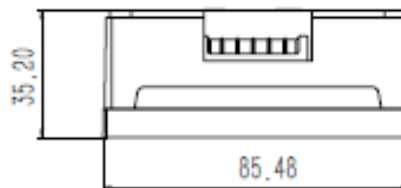
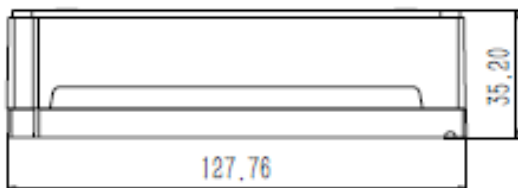

89-4033 & 89-4053

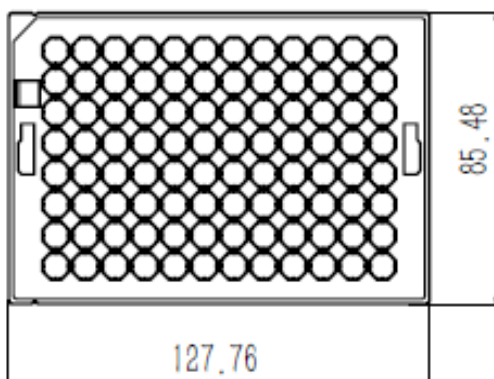
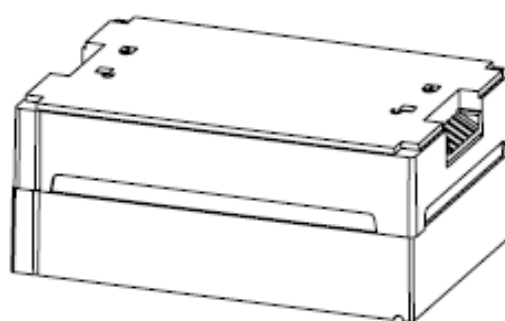
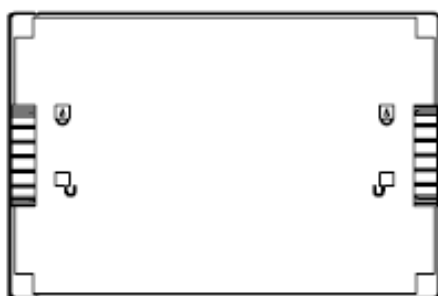
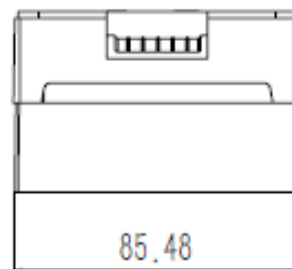
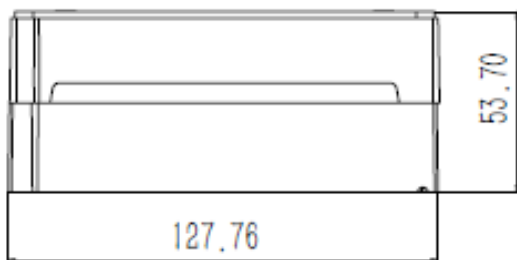

89-4083 & 89-4103